

SEAVIEW

VERTICAL ENTRY: ROUND CABLE SEAL DIMENSIONS

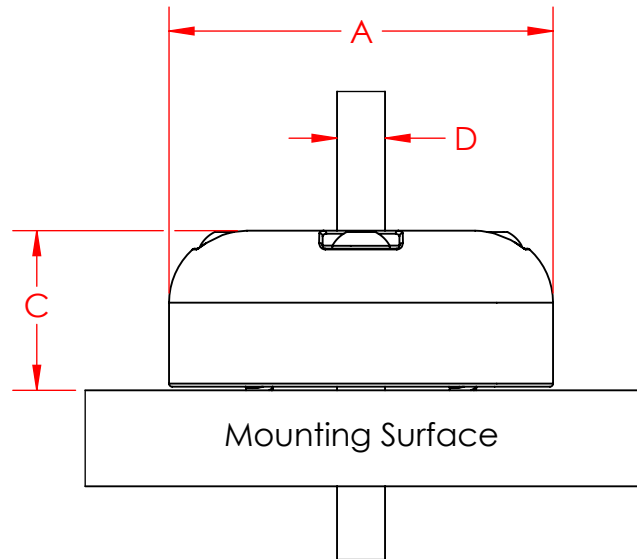
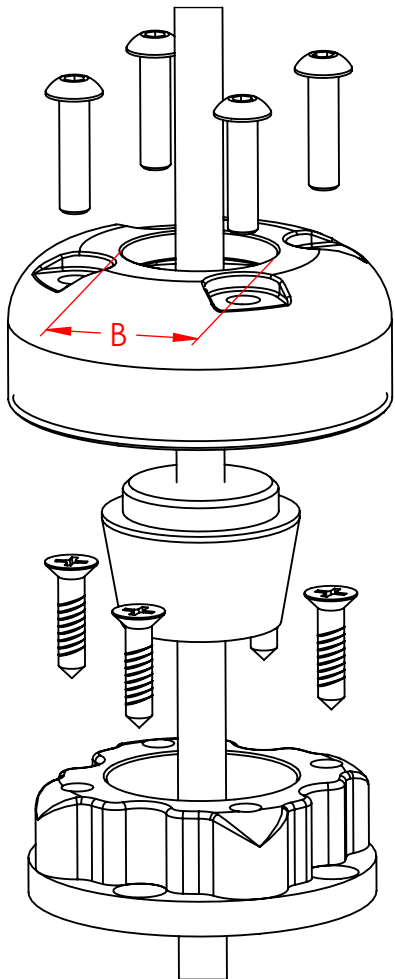
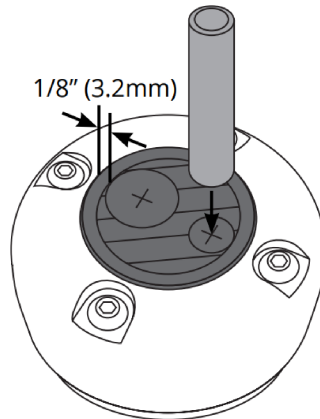

FIGURE 1



- You can use multiple cables for any Seaview cable seal as long as each cable has its own hole and 0.125" (3.2mm) of rubber around each hole. See Figure 1.

- **A** (outer diameter), **B** (max. cable connector diameter), **C** (height), **D** (max. cable diameter)

- For help, e-mail info@seaviewglobal.com;
ph. 1-800-655-7922

PART #	A	B	C	D
CG20PG	2.00" [50.8mm]	0.81" [20.6mm]	0.81" [20.6mm]	0.53" [13.5mm]
CG20PB	2.00" [50.8mm]	0.81" [20.6mm]	0.81" [20.6mm]	0.53" [13.5mm]
CG20PW	2.00" [50.8mm]	0.81" [20.6mm]	0.81" [20.6mm]	0.53" [13.5mm]
CG20SB	2.00" [50.8mm]	0.81" [20.6mm]	0.81" [20.6mm]	0.53" [13.5mm]
CG20SS	2.00" [50.8mm]	0.81" [20.6mm]	0.81" [20.6mm]	0.53" [13.5mm]
CG20SW	2.00" [50.8mm]	0.81" [20.6mm]	0.81" [20.6mm]	0.53" [13.5mm]
CG30PG	2.53" [64.3mm]	1.38" [35.1mm]	0.81" [20.6mm]	1.08" [27.5mm]
CG30PB	2.53" [64.3mm]	1.38" [35.1mm]	0.81" [20.6mm]	1.08" [27.5mm]
CG30PW	2.53" [64.3mm]	1.38" [35.1mm]	0.81" [20.6mm]	1.08" [27.5mm]
CG30SB	2.53" [64.3mm]	1.38" [35.1mm]	0.81" [20.6mm]	1.08" [27.5mm]
CG30SS	2.53" [64.3mm]	1.38" [35.1mm]	0.81" [20.6mm]	1.08" [27.5mm]
CG30SW	2.53" [64.3mm]	1.38" [35.1mm]	0.81" [20.6mm]	1.08" [27.5mm]

SEAVIEW

VERTICAL ENTRY: RETRO FIT ROUND CABLE SEAL DIMENSIONS

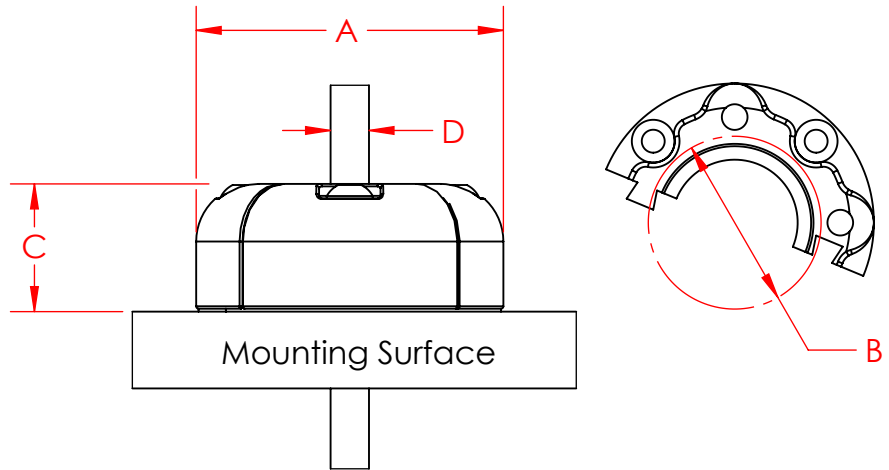
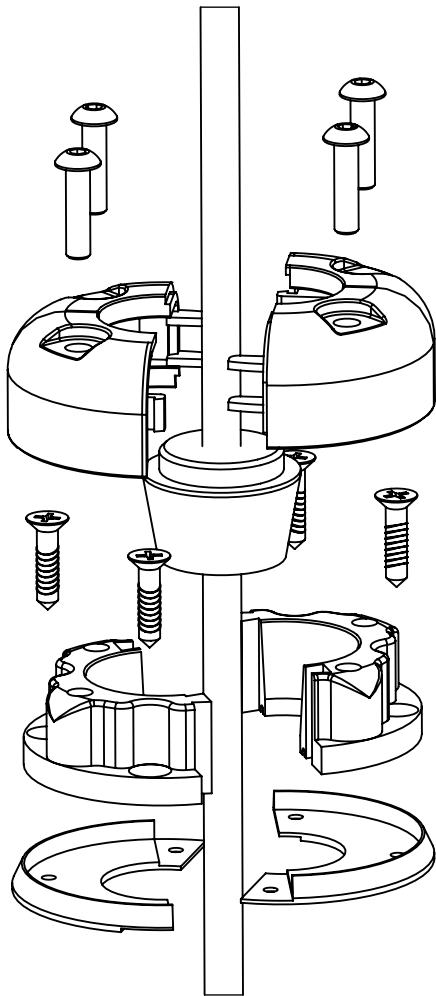
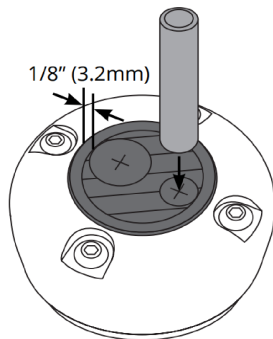

FIGURE 1



- You can use multiple cables for any Seaview cable seal as long as each cable has its own hole and 0.125" (3.2mm) of rubber around each hole. See Figure 1.

- **A** (outer diameter), **B** (max. mounting surface hole diameter), **C** (height), **D** (max. cable diameter)

- For help, e-mail info@seaviewglobal.com; ph. 1-800-655-7922

PART #	A	B	C	D
CG20PG2	2.00" [50.8mm]	1.12" [28.4mm]	0.81" [20.6mm]	0.53" [13.5mm]
CG30PG2	2.53" [64.3mm]	1.62" [41.1mm]	0.81" [20.6mm]	1.08" [27.5mm]

SEAVIEW

VERTICAL ENTRY: RECTANGULAR/MULTI CABLE SEAL DIMENSIONS

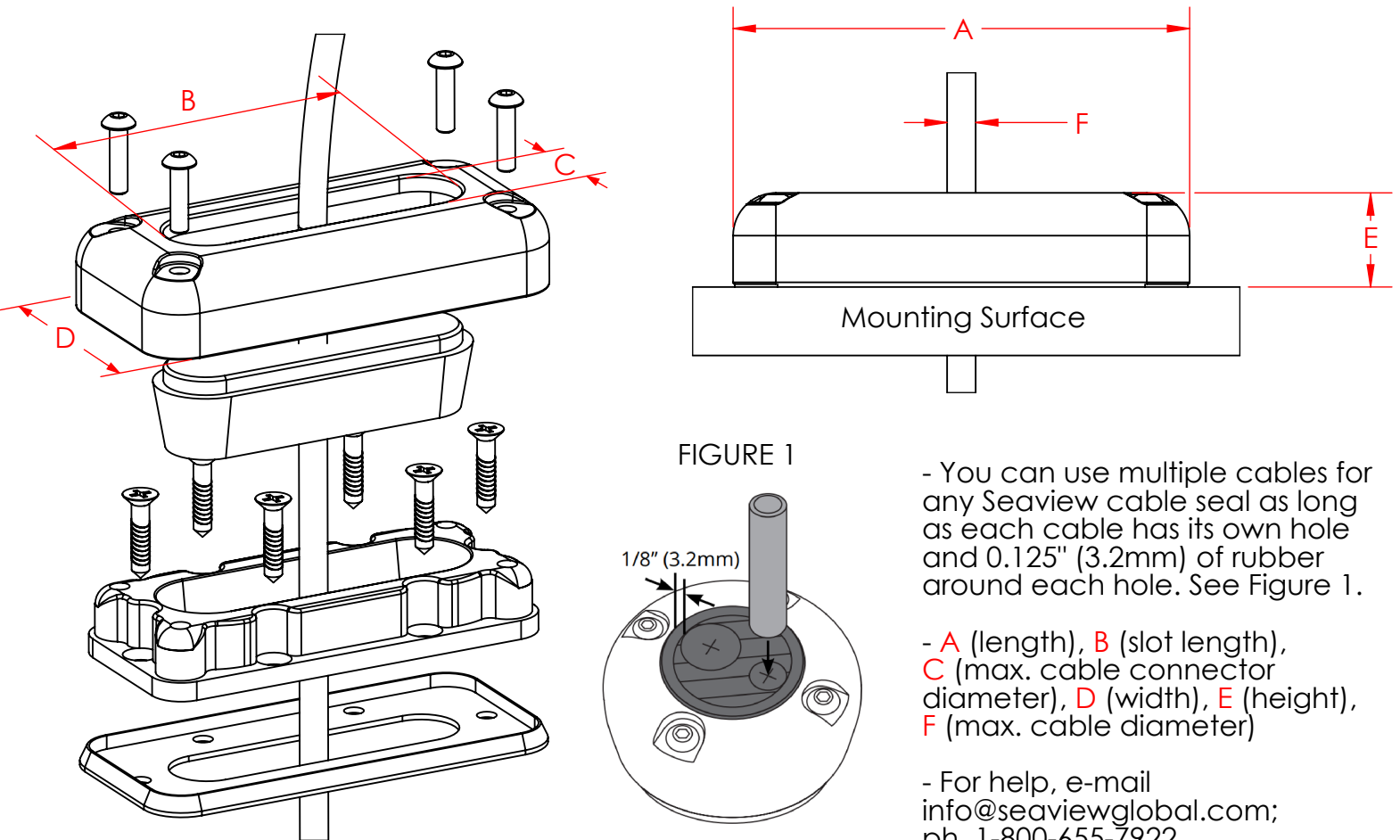

- You can use multiple cables for any Seaview cable seal as long as each cable has its own hole and 0.125" (3.2mm) of rubber around each hole. See Figure 1.

- A (length), B (slot length), C (max. cable connector diameter), D (width), E (height), F (max. cable diameter)

- For help, e-mail info@seaviewglobal.com; ph. 1-800-655-7922

PART #	A	B	C	D	E	F
CGM17PB	4.00" [101.6mm]	2.88" [73.0mm]	0.75" [19.1mm]	1.88" [47.6mm]	0.81" [20.6mm]	0.50" [12.7mm]
CGM17PG	4.00" [101.6mm]	2.88" [73.0mm]	0.75" [19.1mm]	1.88" [47.6mm]	0.81" [20.6mm]	0.50" [12.7mm]
CGM17PW	4.00" [101.6mm]	2.88" [73.0mm]	0.75" [19.1mm]	1.88" [47.6mm]	0.81" [20.6mm]	0.50" [12.7mm]
CGM17SB	4.00" [101.6mm]	2.88" [73.0mm]	0.75" [19.1mm]	1.88" [47.6mm]	0.81" [20.6mm]	0.50" [12.7mm]
CGM17SS	4.00" [101.6mm]	2.88" [73.0mm]	0.75" [19.1mm]	1.88" [47.6mm]	0.81" [20.6mm]	0.50" [12.7mm]
CGM17SW	4.00" [101.6mm]	2.88" [73.0mm]	0.75" [19.1mm]	1.88" [47.6mm]	0.81" [20.6mm]	0.50" [12.7mm]

SEAVIEW

HORIZONTAL ENTRY: CABLE SEAL DIMENSIONS

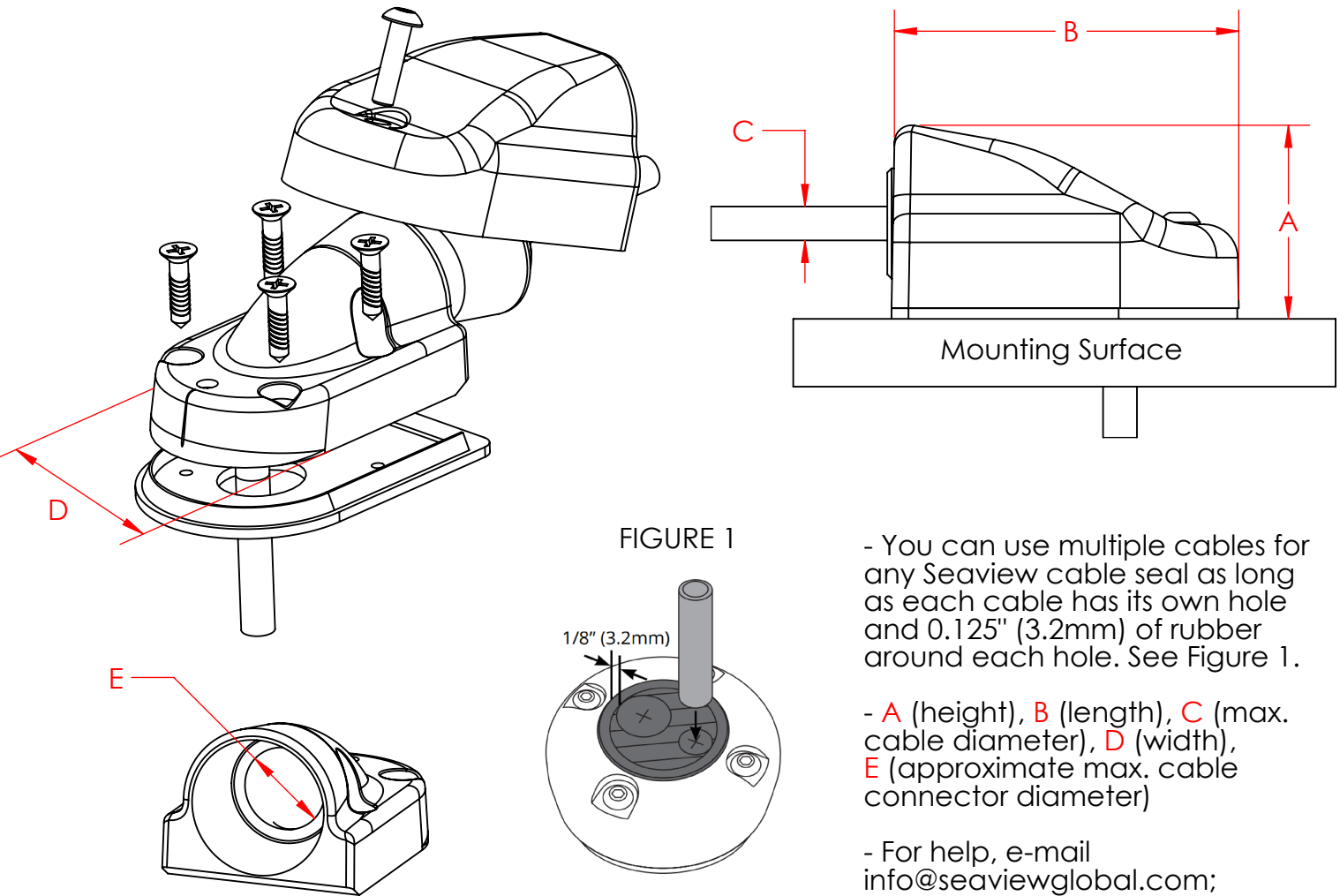

- You can use multiple cables for any Seaview cable seal as long as each cable has its own hole and 0.125" (3.2mm) of rubber around each hole. See Figure 1.

- A (height), B (length), C (max. cable diameter), D (width), E (approximate max. cable connector diameter)

- For help, e-mail info@seaviewglobal.com; ph. 1-800-655-7922

PART #	A	B	C	D	E
CG2090	1.43" [36.3mm]	2.59" [65.8mm]	0.53" [13.5mm]	1.75" [44.5mm]	0.38"-0.50" [9.6mm-12.7mm]
CG2090W	1.43" [36.3mm]	0.38"-0.50" [9.6mm-12.7]	0.53" [13.5mm]	1.75" [44.5mm]	0.38"-0.50" [9.6mm-12.7m]